

NTSE STAGE II

CODE: 13 – 15

SAT

Answer Keys

Held on: June 16, 2019

1.	3	2.	3	3.	4	4.	3
5.	4	6.	2	7.	3	8.	1
9.	3	10.	1	11.	2	12.	3
13.	4	14.	3	15.	2	16.	1
17.	3	18.	3	19.	2	20.	1
21.	4	22.	4	23.	4	24.	3
25.	1	26.	3	27.	1	28.	1
29.	3	30.	1	31.	4	32.	2
33.	2	34.	2	35.	4	36.	3
37.	1	38.	4	39.	3	40.	1
41.	2	42.	4	43.	1	44.	1
45.	1	46.	1	47.	3	48.	3
49.	3	50.	4	51.	2	52.	1
53.	2	54.	2	55.	3	56.	3
57.	3	58.	2	59.	2	60.	1
61.	3	62.	3	63.	2	64.	1
65.	2	66.	4	67.	2	68.	4
69.	1	70.	2	71.	1	72.	3
73.	2	74.	4	75.	1	76.	3
77.	3	78.	2	79.	1	80.	2
81.	4	82.	3	83.	4	84.	3
85.	3	86.	4	87.	3	88.	3
89.	2	90.	3	91.	1	92.	1
93.	4	94.	3	95.	3	96.	3
97.	3	98.	3	99.	1	100.	2

NTSE STAGE II
CODE: 13-15
SAT
Held on: June 16, 2019
Hints & Solutions

1. A set of guidelines called a model code of conduct is enforced during Parliamentary elections in India to avert corrupt practices. This is applied to _____
1. Political parties only
 2. Political parties and voters
 3. Political parties and candidates
 4. Candidates contesting elections only
1. 3
2. A country has the ultimate rights and power to make decisions on internal and external matters. Also it is not dictated by any external power on its decisions relating to its relation with other country.
Which feature is reflected in these statements?
1. Republic
 2. Socialism
 3. Sovereignty
 4. Authoritarian
2. 3
3. Anti-defection law is an important feature of Indian party system. The final authority to decide on the disqualification of a member of the Parliament with respect to anti-defection lies with the _____.
1. President
 2. Prime Minister
 3. Chief Justice the Supreme Court of India
 4. Speaker of the *Lok Sabha* or the Chairman of the *Rajya Sabha*
3. 4
4. Which of the following statements exemplify the independence of judiciary in India?
- I. Judiciary is not under the control of executive and legislature.
 - II. There is less scope for interference in the working of judiciary by the political executive.
 - III. A judge of higher judiciary can be removed only through a resolution which requires 2/3rd majority of both the houses of parliament.
- Choose the correct option.
1. I and II
 2. I and III
 3. I, II and III
 4. II and III
4. 3
5. Rajya Sabha is also called the upper house elders houses and permanent house. Which of the statement/s given below is/are true about it?
- I. Rajya Sabha has more power related to financial matters.
 - II. Rajya Sabha members continue to be in office till the next general election.
 - III. Resolution for removing the Vice-President and the President originates in Rajya Sabha.
 - IV. Number of seats allotted to a state in the Rajya Sabha is directly proportionate to its population.
1. I, II and III
 2. III and IV
 3. I and IV
 4. IV only
5. 4
6. In the context of Indian elections, the parties which fail to gain majority in the Parliament play the role of opposition. Consider the following statements and choose which statement/s is/are is **NOT** true.

- I. Opposition parties in India play an important role in building public opinion.
II. Opposition parties are not constitutionally recognized.
III. Opposition immediately assumes power of government, if the majority party loses its vote of confidence in the Parliament.
IV. Opposition parties keep a close check on the activities of the government.
1. I and II only
2. II and III only
3. III only
4. IV only
6. 2
7. Consider the following statements:
Statement I: All countries that are democratic have written constitution.
Statement II: All countries that have written constitution are not necessarily democratic.
Which of the above statement/s is/are correct?
1. I only
2. II only
3. both I and II
4. Neither I nor II
7. 3
8. China exports a toy to India at Rs 150, whereas the same toy is manufactured and available in India for Rs 250. When China continues to export this toy to India, this trade practice is known as_____.
1. dumping
2. export proportion
3. import substitution
4. export subsidisation
8. 1
9. Shruti and Gautami were discussing about India's GDP and Kerala's SDP. Some of the observations made were:
- I. Kerala's per capita SDP is India's GDP divide by Kerala's population in a particular year.
II. Since Kerala has best literacy rate and excellent quality of life indices, it must have the highest SDP.
III. In a federal structure if we know all the SDPs we can have a fair idea of how big India's GDP will be in that year.
IV. Kerala's per capita SDP in a particular year is the value of all final goods and services produced by the Kerala state in that year divided by Kerala's population in that year.
- Which of the above statements are correct?
1. I and III
2. II and III
3. III and IV
4. I, III and IV
9. 3
10. Shehnaaz joined a coaching institute for a professional course. At the time of joining the course, she paid a lump sum fee for the entire course of two years. However, she did not find the quality of teaching satisfactory and decided to quit after one year. When she asked for a refund of the fee for one year, she was refused. Which of the following right/s of Shehnaaz was/were violated?
- I. Right to choose
II. Right to represent
III. Right to be informed
IV. Right to seek redressal
1. only I
2. I and IV
3. III and IV
4. only IV
10. 1
11. Which of the following reflects situation where a person is employed but do not contribute in adding to the total product?
- I. Open unemployment
II. Disguised unemployment
III. Seasonal unemployment
IV. Frictional unemployment
1. I and II
2. only II
3. III and IV
4. only IV
11. 2
-

12. There are 100 households in the village of Awangkhol, of which the loan taken by 20 households are from the State Bank of India, another 20 households from their friends and relatives, 5 households from Indian Bank, 10 households from a Regional Rural Bank, 15 households from businessmen, 10 households from village headmen and 20 households from cooperative societies. Which of the following inference(s) is/are correct?
- Formal sources of credit are lower than the others.
 - Institutional sources of credit are higher than others.
 - Non-institutional sources of credit are higher than others.
 - Informal sources of credit are slightly higher than others.
1. only I 2. I and II
3. only II 4. III and IV

12. 3
13. Which of the following statements are true about food security?
- Landless people always have food insecurity.
 - Those who do not have enough nutritious food are food insecure.
 - Those who have enough food but not the requisite nutrition are food secure.
 - Those who do not have enough purchasing power to buy sufficient food are food insecure.
1. I and III 2. I and IV
3. II and III 4. II and IV

13. 4
14. Siddhik issues a cheque of Rs 19,000 in favour of Hanush. What happens when the cheque is received and processed in Hanush's bank?
- There is no change in their bank accounts.
 - Both their bank balances increase by Rs 19,000.
 - Siddhik's bank balance decreases by Rs 19,000 and Hanush's bank balance increases by the same amount.
 - There is no change in Siddhik's bank balance although Hanush's bank balance sees an increase.

- Based on the above statements which option is correct?
1. only I 2. I and III
3. only III 4. III and IV

14. 3

15. The daily wage of a person in rural area is Rs 180. Arrange the following households in descending order of vulnerability to poverty.

Name of the Households	Person – days of employment	Size of the Household	Working members of the family
Rulddo	14	4	2
Mulkha	15	7	2
Fakira	10	5	4
Preeto	12	6	3

1. Preeto > Mulkha > Fakira > Rulddo 2. Mulkha > Preeto > Rulddo > Fakira
3. Mulkha > Rulddo > Preeto > Fakira 4. Rulddo > Fakira > Mulkha > Preeto
15. 2

16. The following graph shows the distribution of mean monthly temperature and average rainfall of a particular city during the year.

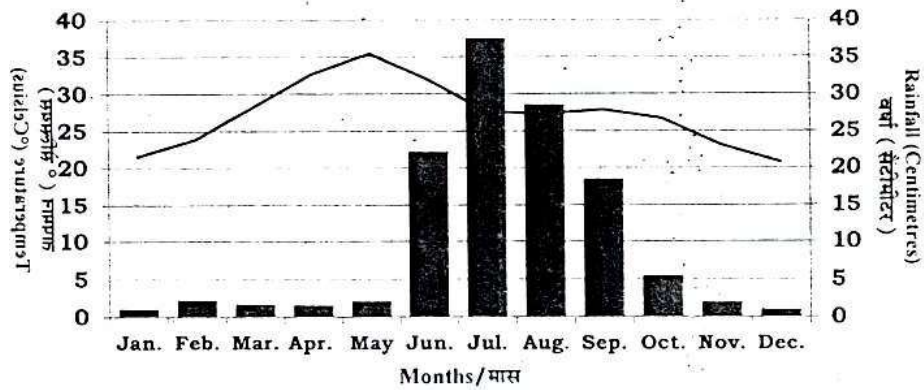

Which one of the following cities shows the climatic conditions presented in the above graph?

1. Nagpur
2. Chennai
3. Jodhpur
4. Bengaluru

16. 1

17. The average mean monthly temperatures of four stations are given in the following table. The temperature is influenced by the movements of land and sea breezes.

MONTHS												
Temperature in Degree Celsius												
Stations	JAN	FEB	MAR	APR	MAY	JUN	JUL	AUG	SEP	OCT	NOV	DEC
A	14.4	16.7	29.3	30.0	33.3	33.3	30.0	29.4	28.9	25.6	19.4	15.6
B	16.8	19.2	26.6	29.8	33.3	33.9	31.3	29.0	20.1	27.0	20.1	14.9
C	24.5	25.7	27.7	30.4	33.0	32.5	31.0	30.2	29.8	28.0	25.9	24.7
C	21.5	23.9	28.3	32.7	35.5	32.0	27.7	27.3	27.9	26.7	23.1	20.7

Which one of these stations experiences maximum moderating influence of the land and sea breezes?

1. A
2. B
3. C
4. D

17. 3

18. Observe the data given in the following table.

City	Female Literacy Rate (%)	Male Literacy Rate (%)	Sex-Ratio
A	66.77	85.38	960
B	71.16	82.67	980
C	73.78	77.17	989
D	59.26	79.24	972

Based on the above table, identify the city which has the extent of equality between male and female better than the rest in terms of the given parameters?

1. A
2. B
3. C
4. D

18. 3

19. Ruhani observes sequential change in relation to altitudinal zones and natural vegetation types dominated by *oak-chestnut*, *pine-deodar* and *silver fir-birch*.

1. Alpine to Temperate to Subtropical
2. Subtropical to Temperate to Alpine
3. Subtropical to Alpine to Temperate
4. Temperate to Alpine to Subtropical

19. 2

20. Observe the map given below.

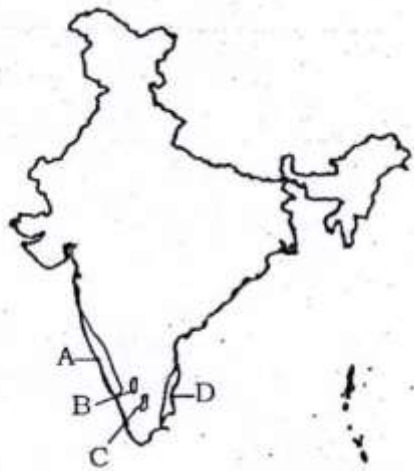

Identify the shaded regions with their corresponding geographical features and select the correct option using the codes given below.

1. A = Zone of laterite soil, B = Coffee producing area, C = Cotton textile, D = Evergreen forest cover
2. A = Evergreen forest cover, B = Coffee producing area, C = Zone of laterite soil, D = Cotton textile industries.
3. A = Evergreen forest cover, B = Zone of laterite soil, C = Coffee producing area, D = Cotton textile industries
4. A = Cotton textile industries, B = Coffee producing area, C = Zone of laterite soil, D = Evergreen forest cover

20.

1

21. Which of the following geological sequence properly matches the tectonic events from old to recent time periods?

1. Formation of Aravalli– Deccan volcanism – formation of Shiwalik – Upliftment of Himadri
2. Deccan volcanism– Formation of Aravalli – Upliftment of Himadri– formation of Shiwalik
3. Deccan volcanism– Formation of Shiwalik – Upliftment of Himadri – Formation of Aravalli
4. Formation of Aravalli– Deccan volcanism – Upliftment of Himadri – Formation of Shiwalik

21.

4

22. The given map shows location of different mountain peaks in India.

PRACTICE QUESTIONS



- A mountaineer wants to scale the mountain peaks in Peninsular India starting from North to South. Identify the correct sequence of peaks the mountaineer will follow?
1. A = Mahendragiri; B = Anaimudi; C = Dodabetta; D = Mahabaleshwar
 2. A = Dodabetta; B = Mahabaleshwar; C = Mahendragiri; D = Anaimudi
 3. A = Anaimudi; B = Mahendragiri; C = Dodabetta; D = Mahabaleshwar
 4. A = Mahendragiri; B = Mahabaleshwar; C = Dodabetta; D = Anaimudi
22. 4
23. While teaching a topic on agriculture geography teacher had made the following statement about a particular crop in her class. "Mean Monthly Temperature of about 27 °C high relative humidity, rainfall of 150 cm in summer months and khaddar soils are the ideal physical requirements during the period of its vegetative growth." Which one of the following crops was stated by the teacher?
1. Tea
 2. Jute
 3. Rubber
 4. Sugarcane
23. 4
24. Bibhuti was travelling to study the traditional agricultural practices among various communities in Meghalaya, Jharkhand, Odisha and Western Ghats. Identify the correct sequence of forms of cultivation practiced in these regions.
1. Jhumming – Kumari – Pama Dabi – Kuruwa
 2. Kuruwa – Pama Dabi – Jhumming – Kumari
 3. Jhumming – Kuruwa – Pama Dabi – Kumari
 4. Pama Dabi – Kumari – Jhumming – Kuruwa
24. 3
25. River Indus flows through Leh and Kargil districts in the state of Jammu and Kashmir. It has four major tributaries in India. Which one of the following is the correct sequence of the tributaries arranged from East to West in terms of their confluence with river Indus?
1. Zaskar – Dras – Hunza – Shyok
 2. Zaskar – Hunza – Dras – Shyok
 3. Hunza – Dras – Zaskar – Shyok
 4. Zaskar – Dras – Shyok – Hunza
25. 1
26. A tourist was traveling Indian States and came across a famous *Buddhist Monastery*, *farming of three rice crops within the same agricultural year*, *a cement factory and floating gardens on a lake*. Identify the proper sequence of the States the tourist travelled.
1. Sikkim – West Bengal – Assam – Meghalaya

2. Sikkim – Arunachal Pradesh – Assam – Manipur
3. Arunachal Pradesh – Assam – Meghalaya – Manipur
4. Arunachal Pradesh – West Bengal – Manipur – Meghalaya

26.

27. Observe the following diagrams carefully.

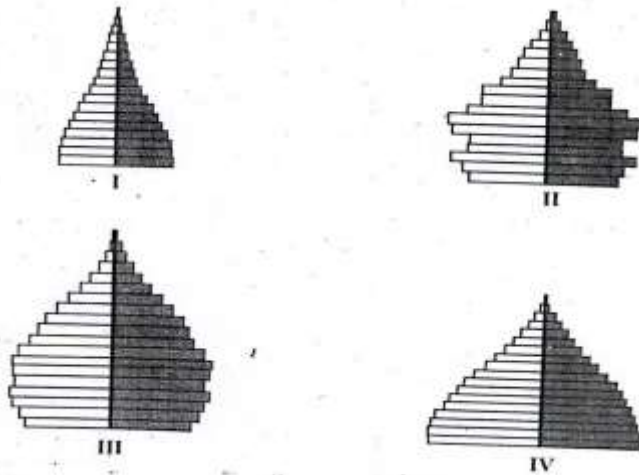

Which one of the above population pyramids is an ideal representation of India's population?

1. I
2. II
3. III
4. IV

27.

28. Which of the following statements regarding printing in Medieval Europe are correct?

- I. Wood block printing reached Europe in the 13th Century.
- II. The aristocrats and monks criticized printed books as cheap vulgarities in the beginning.
- III. Printing did not entirely displace the art of producing books by hand.
- IV. Martin Luther had reservations against printing of books.

1. I, II and III
2. I, III and IV
3. I, II and IV
4. II, III and IV

28.

29. Which of the following statements related to Mahatma Gandhi's view on Satyagraha are correct?

- I. The movement in South Africa was not passive resistance.
- II. It is the weapon of the people, who are not weak.
- III. India could not militarily face Britain.
- IV. Truth is the supreme *dharma*

1. I, II and III
2. I, II and IV
3. II, III and IV
4. I, III and IV

29.

30. Which of the following statements relating to the 'Scorched Earth Policy' in Java are correct?

- I. The Dutch destroyed the saw mills.
- II. Teak logs were burnt by the Dutch.
- III. Trees were cut freely to meet war needs.
- IV. The villagers were encouraged to expand cultivation in the forest areas.

1. I and II
2. I, II and III
3. I and IV
4. II, III and IV

30.

31. Which of the following statements about opium cultivation in India during the British period are correct?

- I. The peasants could sell off the produce freely.

31.

- II. Local traders offered higher prices for opium.
- III. Opium production was increasing in territories that were not under the British.
- IV. Peasants were getting money advances from the village headman to produce opium.

- 1. I, II and III
- 2. I, II and IV
- 3. I, III and IV
- 4. II, III and IV

31. 4

32. Observe the given picture taken from *New Orleans, Illustrated London News*, 1851

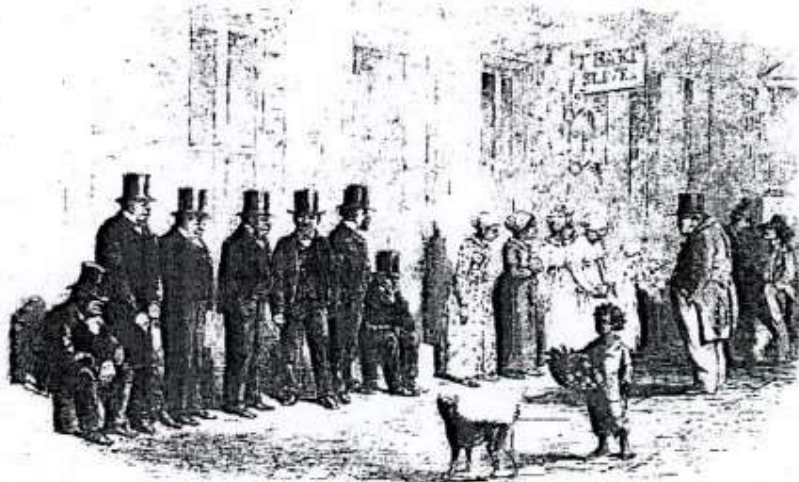

What does the picture represent?

- 1. Mourning
- 2. Slave auction
- 3. Market place
- 4. Roadside gathering

32. 2

33. Why were Nghe An and Ha Tinh provinces called 'electrical fuses' of Vietnam?

- 1. They were near to the capital city and were centers of power.
- 2. They were among the poorest provinces and had an old radical tradition.
- 3. They were very rich and had strong trade links with the outer world.
- 4. They were at the borders and were in conflicts with the neighboring countries.

33. 2

34. Which of the following would be the part of the surroundings in a *chawl* in Bombay during the colonial period?

- I. Large number of people living in shared rooms.
- II. A large population of people belonging to depressed and lower classes.
- III. Streets and neighbourhood being used for a variety of activities such as cooking, washing and sleeping.
- IV. Liquor shops and *Akharas* in any open spot.

- 1. I, II and III
- 2. I, III and IV
- 3. II and III
- 4. II, III and IV

34. 2

35. Which of the following statements are true in the context of Cricket in Victorian England?

- I. The rules of Cricket were made to favour those who were described as "players".
- II. The wages of professionals were paid by patronage or subscription or gate money.
- III. Cricket was viewed as a way of teaching English boys discipline, importance of hierarchy and leadership qualities.
- IV. The rich who played were called amateurs.

- 1. I, II and III
- 2. I, II and IV
- 3. I, III and IV
- 4. II, III and IV

35. 4

36. Which of the following statements are true for eighteenth century France?

- I. There was much criticism of slavery.
- II. The National Assembly feared opposition from businessmen who were dependant on slave trade.
- III. Plantation owners understood their freedom as including the right to enslave Africans.
- IV. The Convention of 1791 legislated to free all slaves in the French overseas possessions.

- 1. I and II
- 2. I, II and IV
- 3. II and III
- 4. II, III and IV

36. 3

37. Which of the following statements are true in the context of Liberals in Modern Europe?

- I. They opposed the uncontrolled power of dynastic rulers.
- II. They wanted to safeguard the rights of individuals against governments.
- III. They argued for Independent judiciary.
- IV. They believed in universal adult franchise for all men and women with property.

- 1. I, II and III
- 2. I, II and IV
- 3. I, III and IV
- 4. II, III and IV

37. 1

Directions : (Questions 38 – 40)

Read the statements and select the correct answer from the options given below:

- 1. Statement I is true, Statement II is false.
- 2. Statement I is false, Statement II is true
- 3. Both statements are true, and Statement II provides explanation of Statement I
- 4. Both Statements are true but Statement II does not provide explanation to Statement I.

38. Statement I : The Bretton Woods System came up during the post World War Period.
Statement II : The industrial nations had massive growth of trade and incomes.

38. 4

39. Statement I : Potatoes had been discovered by the European in the Americas.
Statement II: Poor people in Ireland were dependent on potatoes to escape starvation in the 19th century.

39. 3

40. Statement I : The President of India cannot claim the kind of direct mandate that the Prime Minister of India can.
Statement II : A candidate contesting for the post of President has to gain a majority of votes to be elected as the President of India.

40. 1

41. If $m = n^2 - n$, where n is an integer, then $m^2 - 2m$ is divisible by

- 1. 20
- 2. 24
- 3. 30
- 4. 16

41. 2

Sol. $m = n^2 - n$
So, $m^2 - 2m$
 $= (n^2 - n)^2 - 2(n^2 - n)$
 $= (n - 2)(n - 1)(n)(n + 1) \Rightarrow$ divisible by 24.

42. The value of $\sqrt{97 \times 98 \times 99 \times 100 + 1}$ is equal to

- 1. 9901
- 2. 9891
- 3. 9801
- 4. 9701

42. 4

Sol. $n = 97$

$$\begin{aligned}
& \sqrt{97 \times 98 \times 99 \times 100 + 1} \\
&= \sqrt{n(n+1)(n+2)(n+3) + 1} \\
&= \sqrt{(n^2 + 3n)(n^2 + 3n + 2) + 1} \quad [\text{Put } n^2 + 3n = k] \\
&\Rightarrow \sqrt{k(k+2) + 1} \\
&= \sqrt{k^2 + 2k + 1} \\
&= k + 1 \\
&= n^2 + 3n + 1 \\
&= n(n+3) + 1 \\
&= 97(100) + 1 \\
&= 9701
\end{aligned}$$

43. Let $P(x)$ be a polynomial of degree 3 and $P(n) = \frac{1}{n}$ for $n = 1, 2, 3, 4$. Then the value of $P(5)$

is

1. 0

2. $\frac{1}{5}$

3. $-\frac{2}{5}$

4. $\frac{3}{5}$

43. 1

Sol. $P(n) = \frac{1}{n}$ for $n = 1, 2, 3, 4$

$$\Rightarrow nP(n) - 1 = 0 \text{ for } n = 1, 2, 3, 4$$

$$\Rightarrow nP(n) - 1 = 0 \text{ is a degree 4 polynomial having roots } 1, 2, 3, 4$$

$$\Rightarrow nP(n) - 1 = k(n-1)(n-2)(n-3)(n-4) \text{ comparing constant term on both sides}$$

$$-1 = 24k \Rightarrow k = -\frac{1}{24}$$

$$\text{So, } nP(n) = -\frac{1}{24}(n-1)(n-2)(n-3)(n-4) + 1$$

$$\text{Putting } n = 5, \text{ we get, } 5P(5) = 0$$

$$\Rightarrow P(5) = 0$$

44. If α and β are the roots of the equation $3x^2 - 5x + 3 = 0$, then the quadratic equation whose roots are $\alpha^2\beta$ and $\alpha\beta^2$ is

1. $3x^2 - 5x + 3 = 0$

2. $3x^2 - 8x + 5 = 0$

3. $3x^2 - 8x + 3 = 0$

4. $3x^2 - 5x - 3 = 0$

44. 1

Sol. $3x^2 - 5x + 3 = 0$

$$\alpha + \beta = \frac{5}{3}$$

$$\alpha\beta = 1$$

$$\alpha^2\beta + \alpha\beta^2 = \alpha\beta(\alpha + \beta) = \frac{5}{3}$$

$$\alpha^2\beta \times \alpha\beta^2 = (\alpha\beta)^3 = 1$$

\therefore required polynomial is:

$$x^2 - \frac{5}{3}x + 1 = 0$$

$$3x^2 - 5x + 3 = 0$$

45. In village Madhubani, 8 women and 12 girls can paint a large mural in 10 hours. 6 women and 8 girls can paint it in 14 hours. The number of hours taken by 7 women and 14 girls to paint the mural is

1. 10
2. 15
3. 20
4. 35

45. 1

Sol. $8w + 12g = \frac{1}{10}$
 $6w + 8g = \frac{1}{14}$

Solving, we get, $w = \frac{1}{140}$, $g = \frac{1}{280}$

\therefore Time required by 7 women and 14 girls
 $= \frac{7}{\frac{1}{140}} + \frac{14}{\frac{1}{280}} = \frac{1}{\frac{1}{10}} = 10$ hrs.

46. If $x = \frac{3 + \sqrt{5}}{2}$ and $y = x^3$, then y satisfies the quadratic equation

1. $y^2 - 18y + 1 = 0$
2. $y^2 + 18y + 1 = 0$
3. $y^2 - 18y - 1 = 0$
4. $y^2 + 18y - 1 = 0$

46. 1

Sol. $x = \frac{3 + \sqrt{5}}{2}$

$$\Rightarrow 2x - 3 = \sqrt{5}$$

$$\Rightarrow 4x^2 - 12x + 9 = 5 \quad (\text{Squaring both sides})$$

$$\Rightarrow 4x^2 - 12x + 4 = 0$$

$$\Rightarrow x^2 - 3x + 1 = 0$$

Now, $x = y^{1/3}$

$$\Rightarrow y^{2/3} - 3y^{1/3} + 1 = 0$$

$$\Rightarrow y^{2/3} - 3y^{1/3} = -1 \quad (\text{Cubing both sides})$$

$$\Rightarrow y^2 - 27y - 3y^{2/3} \cdot 3y^{1/3} (y^{2/3} - 3y^{1/3}) = -1$$

$$\Rightarrow y^2 - 27y - 9y(-1) + 1 = 0$$

$$\Rightarrow y^2 - 18y + 1 = 0$$

47. If $\tan^2 \theta = 1 - e^2$, then the value of $\sec \theta + \tan^3 \theta \operatorname{cosec} \theta$ is equal to

1. $(1 - e^2)^{1/2}$
2. $(2 - e^2)^{1/2}$
3. $(2 - e^2)^{3/2}$
4. $(1 - e^2)^{3/2}$

47. 3

Sol. $\tan^2 \theta = 1 - e^2 \Rightarrow \sec^2 \theta = 2 - e^2$

$$\sec \theta + \tan^3 \theta \operatorname{cosec} \theta$$

$$= \sec \theta + \tan^2 \theta \cdot \frac{\sin \theta}{\cos \theta} \cdot \frac{1}{\sin \theta}$$

$$= \sec \theta (1 + \tan^2 \theta)$$

$$\begin{aligned}
 &= \sec \theta (\sec^2 \theta) \\
 &= \sec^3 \theta \\
 &= (2 - e^2)^{3/2}
 \end{aligned}$$

48. Let the volume of a solid sphere be $288\pi\text{cm}^3$. A horizontal plane cuts the sphere at a distance of 3 cm from the centre so that the ratio of the curved surface areas of the two parts of the sphere is 3 : 1. The total surface area of the bigger part of the sphere (in cm^2) is
1. 36π
 2. 108π
 3. 135π
 4. 144π

48. 3
 Sol. $\frac{4}{3}\pi r^3 = 288\pi \Rightarrow r = 6$

Let a, b and c represent the CSA of the 3 portions shown in the figure.

$$\Rightarrow a + b + c = \text{Total surface area} = 4\pi(6)^2 = 144\pi$$

$$\frac{a+b}{c} = \frac{3}{1} \Rightarrow \frac{a+b+c}{c} = \frac{4}{1}$$

$$c = \frac{1}{4} \times 144\pi = 36\pi \quad a + b = 3 \times 36\pi = 108\pi$$

$$k^2 = 36 - 9 = 27$$

$$\text{Flat surface area of larger part} = \pi k^2 = 27\pi$$

$$\therefore \text{Total surface area of larger part} = 108\pi + 27\pi = 135\pi$$

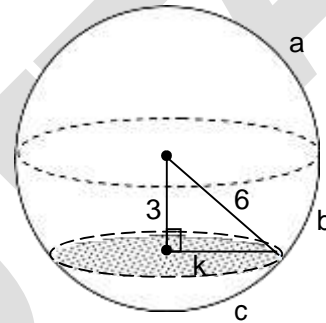

49. A solid metallic cylinder of height 10 cm and diameter 14 cm is melted to make two cones in the proportion of their volumes as 3 : 4, keeping the height 10 cm, what would be the percentage increase in the flat surface area?
1. 9
 2. 16
 3. 50
 4. 200

49. 3
 Sol. Let volumes of the two cones be $3x$ and $4x$

$$7x = \pi(10)(7^2)$$

$$x = 70\pi$$

$$\therefore \text{Volumes are } 210\pi \text{ and } 280\pi$$

$$\therefore \text{Radius of cones are } 3\sqrt{7} \text{ and } 2\sqrt{21}$$

$$\begin{aligned}
 \therefore \text{new flat area} &= \pi \left((3\sqrt{7})^2 + (2\sqrt{21})^2 \right) \\
 &= 147\pi
 \end{aligned}$$

$$\text{Original flat area} = 2\pi(7^2) = 98\pi$$

$$\therefore \text{Increase \%} = 50\%$$

50. Each vertical face of square based vertical pillar of height 3 m has 7 equal, semi-cylindrical surfaces in such a way that its horizontal cross-section is as shown in the figure.

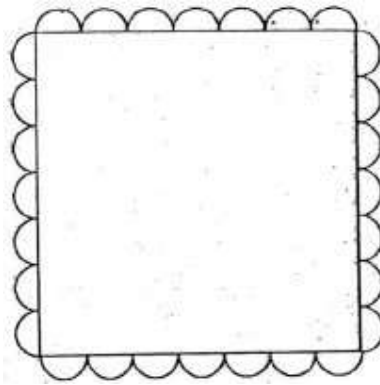

If the radius of each semi circle is 10 cm, the volume (in m^3) of the pillar so designed (taking $\pi = \frac{22}{7}$) is

1. 5.88
2. 6.14
3. 6.42
4. 7.2

50.

4

Sol.

Required volume

= Volume of cuboid + 14 x volume of cylinder

$$= 1.4 \times 1.4 \times 3 + 14 \times \pi \times (0.1)^2 \times 3$$

$$= 3 (1.96 + (44 \times 0.01))$$

$$= 3 (1.96 + 0.44)$$

$$= 3(2.4)$$

$$= 7.2\text{m}^3$$

51. Let ABCD be a square of side 20 cm. The area of the square PQRS (in cm^2) interior to ABCD, shown in the figure is

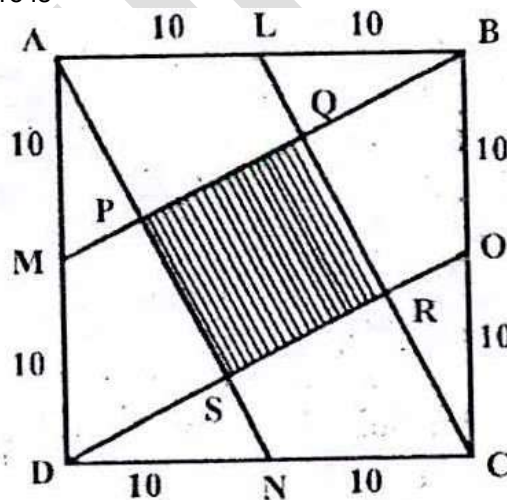

1. 60
2. 80
3. 100
4. 400

51.

2

Sol.

ALCN will be parallelogram

So In $\triangle BAP$, $LQ \parallel AP \Rightarrow Q$ is midpoint of BP

$$\Rightarrow \frac{\text{ar}(\text{LQB})}{\text{ar}(\text{ABP})} = \frac{1}{4} = \frac{x}{4x} \quad (\text{let}) \Rightarrow \text{ar}(\text{ALQP}) = 3x$$

Since $\text{ar}(\text{APM}) = \text{ar}(\text{BQL}) = x$

$$\Rightarrow \text{ar}(\triangle BAM) = 5x = \frac{1}{2} \times 20 \times 10 \Rightarrow x = 20$$

$$\text{So, area of square PQRS} = 400 - 16x \\ = 80$$

52. A circle is inscribed in a right angled triangle of perimeter 7π . Then the ratio of numerical values of circumference of the circle to the area of the right angled triangle is

1. 4 : 7
2. 3 : 7
3. 2 : 7
4. 1 : 7

52. 1

Sol. We have $\Delta = sr = \frac{7\pi r}{2}$

$$\text{Now } \frac{2\pi r}{\Delta} = \frac{2\pi r}{\frac{7\pi r}{2}} = \frac{4}{7}$$

53. It is known that area of a cyclic quadrilateral is $\sqrt{(s-a)(s-b)(s-c)(s-d)}$ where a, b, c, d are the sides and $s = \frac{a+b+c+d}{2}$.

If a circle can also be inscribed in the cyclic quadrilateral then the area of this quadrilateral is

1. $\sqrt{(ab)^2 + (cd)^2}$
2. \sqrt{abcd}
3. $\sqrt{(ac)^2 + (bd)^2}$
4. $\sqrt{(ad)^2 + (bc)^2}$

53. 2

Sol. If a circle can be inscribed in a quadrilateral having sides a, b, c and d then $a + c = b + d$

$$\text{Now } s = \frac{a+b+c+d}{2} = a + c = b + d$$

$$\text{Area of cyclic quadrilateral} = \sqrt{(s-a)(s-b)(s-c)(s-d)}$$

$$= \sqrt{[s^2 - (a+c)s + ac][s^2 - (b+d)s + bd]}$$

$$= \sqrt{abcd}$$

54. Two circles, both of radii 'a' touch each other and each of them touches internally a circle of radius 2a. Then the radius of the circle which touches all the three circles is

1. $\frac{1}{2}a$
2. $\frac{2}{3}a$
3. $\frac{3}{4}a$
4. a

54. 2

Sol. Let required radius be 'r'

$$AB = r + a$$

$$BC = 2a$$

$$AD = 2a - r$$

$$\therefore (2a - r)^2 + a^2 = (r + a)^2$$

$$\Rightarrow r = \frac{2}{3}a$$

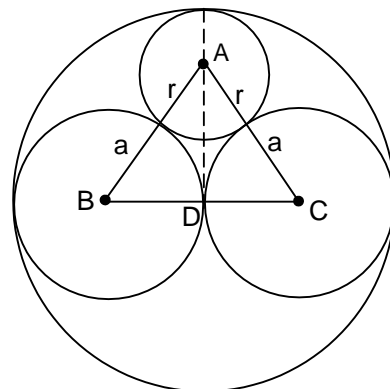

55. Let D be a point on the side BC of a triangle ABC such that $\angle ADC = \angle BAC$. If AC = 21 cm, then the side of an equilateral triangle whose area is equal to the area of the rectangle with sides BC and DC is

1. $14 \times 3^{1/2}$

2. $42 \times 3^{-1/2}$

3. $14 \times 3^{3/4}$

4. $42 \times 3^{1/2}$

55. 3

Sol. $\triangle CDA \sim \triangle CAB$

$$\Rightarrow \frac{CD}{CA} = \frac{AC}{BC}$$

$$\Rightarrow BC \times CD = AC^2 = 441$$

If x is the side of equilateral triangle then

$$\frac{\sqrt{3}}{4} \times x^2 = 441$$

$$\Rightarrow x = 14 \times 3^{3/4}$$

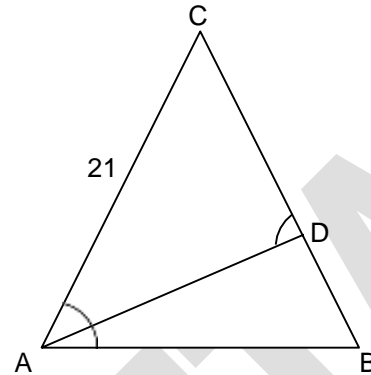

56. Let ABC be a triangle with sides a, b, c. Then lengths of medians of the triangle formed by the medians of the triangle ABC are

1. $\frac{1}{2}a, \frac{1}{2}b, \frac{1}{2}c$

2. $\frac{2}{3}a, \frac{2}{3}b, \frac{2}{3}c$

3. $\frac{3}{4}a, \frac{3}{4}b, \frac{3}{4}c$

4. $\frac{5}{6}a, \frac{5}{6}b, \frac{5}{6}c$

56. 3

Sol. Let original triangle be $\triangle ABC$, with median AD, BE and CF.

Now construct DM parallel and equal to CF.

\Rightarrow MFCD is a parallelogram.

Join AM.

\therefore DM and BF intersect at T.

Now, MFCD is a parallelogram

\Rightarrow MF is equal and parallel to DC

\Rightarrow MF is equal and parallel to BD (DC=BD)

\Rightarrow MFDB is a parallelogram

\Rightarrow FT = TB and DT = TM \Rightarrow AT is median of

$\triangle AMD$.

Similarly, we can prove AM = BE and AM \parallel BE

\Rightarrow AMBE is a parallelogram

\Rightarrow AF = FB

\Rightarrow AF = 2FT

\Rightarrow F is the centroid of $\triangle AMD$ which is the \triangle of medians of $\triangle ABC$.

So, now we have $\frac{AF}{FT} = \frac{2}{1}$ and $\frac{AF}{AB} = \frac{1}{2}$ and $\frac{FT}{TB} = 1$

$$\Rightarrow \frac{AT}{AB} = \frac{3}{4}$$

\therefore median of $\triangle AMD = \frac{3}{4}$ side of ABC

\therefore Answer is $\frac{3}{4}a, \frac{3}{4}b, \frac{3}{4}c$

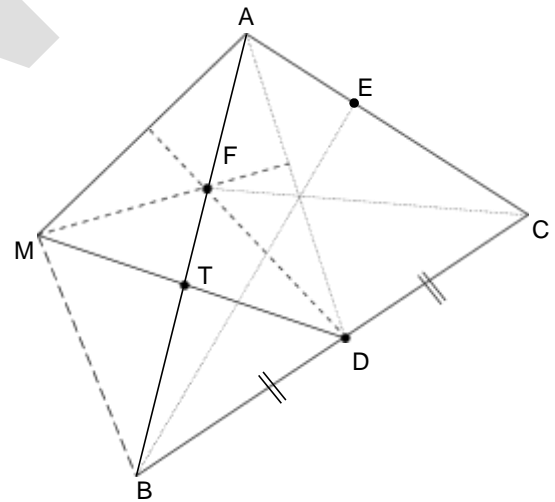

(For shorter approach, during exam time, you may consider a special case of Equilateral Triangle)

57. $(x + 1)^4$ is divided by $(x - 1)^3$. Then the value of the remainder at $x = 1$ is
1. -16
 2. 0
 3. 16
 4. 32

57. **3**

Sol. $(x + 1)^4 = [(x - 1) + 2]^4$
 $= {}^4C_0 (x - 1)^4 2^0 + {}^4C_1 (x - 1)^3 2^1 + {}^4C_2 (x - 1)^2 2^2$
 $+ {}^4C_3 (x - 1)^1 2^3 + {}^4C_4 2^4$

Remainder when $(x + 1)^4$ is divided by $(x - 1)^3$

$$= {}^4C_2 (x - 1)^2 2^2 + {}^4C_3 (x - 1)^1 2^3 + {}^4C_4 2^4$$

Remainder (when $x = 1$) = 16

58. A circle passes through the vertices of a triangle ABC. If the vertices are A(-2, 5), B(-2, -3), C(2, -3), then the centre of the circle is

1. (0, 0)
2. (0, 1)
3. (-2, 1)
4. (0, -3)

58. **2**

Sol. A (-2, 5), B (-2, -3) and C (2, -3)

$$\therefore AB = 8$$

$$BC = 4$$

$$AC = \sqrt{16 + 64} = \sqrt{80}$$

$$\square AB^2 + BC^2 = AC^2$$

$\Rightarrow \therefore$ Given triangle is right angle triangle Right angled at B.

\therefore Circumcentre will be mid point of hypotenuse

$$= \left(\frac{-2+2}{2}, \frac{5-3}{2} \right) = (0, 1)$$

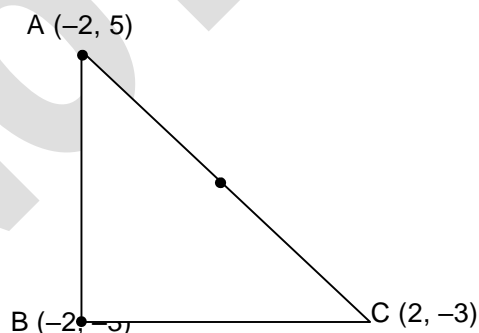

59. If two dice are thrown together, the probability that the difference of the numbers appearing on them is a prime number

1. $\frac{2}{9}$
2. $\frac{4}{9}$
3. $\frac{5}{12}$
4. $\frac{17}{36}$

59. **2**

Sol. Favourable cases are : (6, 4), (4, 6), (5, 3), (3, 5), (2, 4), (4, 2), (3, 1), (1, 3), (6, 3), (3, 6), (5, 2), (2, 5), (1, 4), (1, 6), (4, 1) and (6, 1)

$$\therefore \text{Required probability} = \frac{16}{36} = \frac{4}{9}$$

60. Observe the following data.

Class	0 - 20	20 - 40	40 - 60	60 - 80	80 - 100	Total
Frequency	17	f_1	32	f_2	19	120

If the above data has mean 50, then missing frequencies f_1 and f_2 are respectively

1. 28 and 24
2. 24 and 28
3. 28 and 30
4. 30 and 28

60. 1

Sol.

Mid value	10	30	50	70	90	total
Frequency	17	f_1	32	f_2	19	120

$$f_1 + f_2 = 52$$

$$\text{Mean} = \frac{10 \times 17 + 30f_1 + 50 \times 32 + 70 \times f_2 + 90 \times 19}{120}$$

$$\Rightarrow 50 = \frac{170 + 30f_1 + 1600 + 70f_2 + 1710}{120}$$

$$\Rightarrow 6000 - 3480 = 30f_1 + 70f_2$$

$$\Rightarrow 2520 = 30f_1 + 70f_2$$

$$\Rightarrow 2520 = 30(52 - f_2) + 70f_2$$

$$\Rightarrow 2520 = 1560 + 40f_2$$

$$\Rightarrow f_2 = 24$$

$$\therefore f_1 = 28$$

Directions: (Questions 61 – 62)

Suppose that the acceleration versus time graph of a particle that starts from rest at $t = 0$ is as shown in the figure.

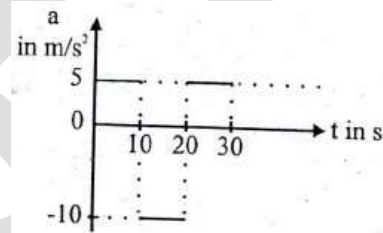

61. At what instant does the particle come to rest for the first time?

1. 5 s

2. 10 s

3. 15 s

4. The particle never comes to rest

61. 3

Sol.

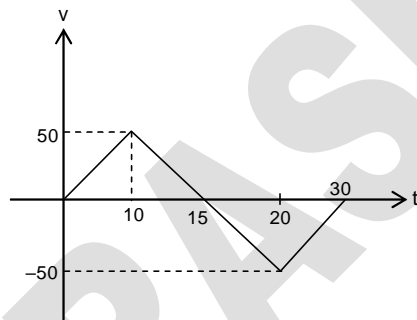

$$V = 0 \text{ at } t = 15 \text{ s and } 30 \text{ s}$$

62. What is the total distance travelled by the particle during 30 s?

1. 0 m

2. 500 m

3. 750 m

4. 1000 m

62. 3

$$\begin{aligned} \text{Sol. Distance} &\Rightarrow \frac{1}{2} \times 15 \times 50 + \frac{1}{2} \times 50 \times 15 \\ &\Rightarrow 25 \times 15 + 25 \times 15 \\ &\Rightarrow 750 \text{ m} \end{aligned}$$

63. An object of mass 2 kg is moving under the action of a force which varies with time as shown in the figure.

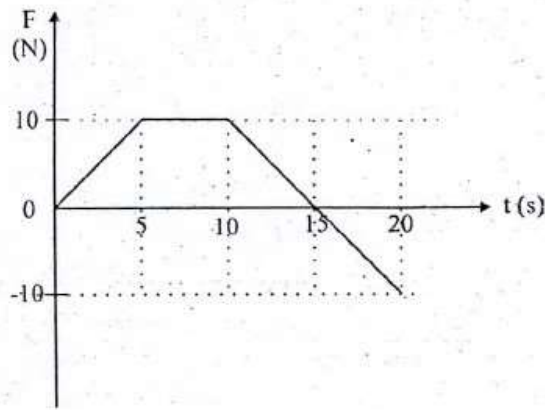

Which one of the following statements is correct for the interval from 0 to 20s?

1. The momentum of the object decreases by 75 kg m/s.
2. The momentum of the object increases by 75 kg m/s.
3. The momentum of the object increases by 125 kg m/s.
4. The change in momentum cannot be found as initial speed is unknown.

63. 2

Sol.
$$\Delta P = \frac{1}{2} \times (5 + 15) \times 10 = \frac{1}{2} \times 10 \times 5$$

$$\Rightarrow 20 \times 5 = 25$$

$$P_f - P_i \Rightarrow 75 \text{ kg m/s}$$

64. Two cars 'A' and 'B' of same mass start from the same location at the same time but on different straight roads. Car 'A' travels on a road that has greater angle of inclination with horizontal compared to the road on which 'B' travels. At any instant both cars 'A' and 'B' have the same height above the starting point. If E_A and E_B are total energies of cars 'A' and 'B' respectively, then

1. $E_A < E_B$
2. $E_A = E_B$
3. $E_A > E_B$
4. Relation between E_A and E_B cannot be decided based on given information.

64. 1

Sol. $\square \square_2 > \square_1$
 So, $a_2 > a_1$
 $V_2 > V_1$

$kE_2 > kE_1$
 $PE_2 = PE_1$
 $TE_2 > TE_1$
 $E_B > E_A$

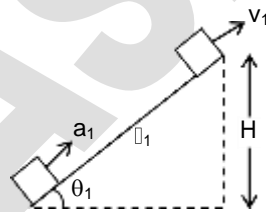

$\theta_1 > \theta_2$

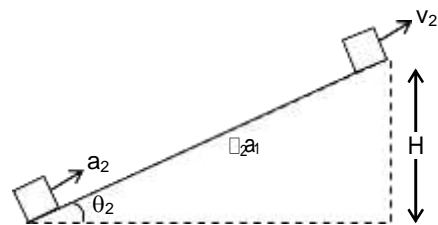

65. The gravitational potential energy difference per unit mass between the surface of a planet and a point 100 m above it is 1000 J/kg. How much work is required to be done in moving a 5 kg object 100 m on a slope at 30° to the horizontal on this planet?

1. 1250 J
2. 2500 J
3. 4350 J
4. 5000 J

65. 2

Sol. Potential energy per unit mass is gravitational potential.

\square Effective height = $100 \sin 30^\circ \Rightarrow 50 \text{ m}$

Work done $\Rightarrow m(\Delta V)$

$\Rightarrow 5(500) = 2500 \text{ J}$

Directions: (Questions 66 – 67)

Two identical objects A and B each of mass m start moving along the same vertical line in opposite directions at the same instant. Object A is dropped from rest from a height H above the ground and object B is projected vertically upward from the ground with speed $u = \sqrt{2gH}$.

66. At what height above the ground do they collide?
 1. $(1/4)H$ 2. $(1/2)H$
 3. $(2/3)H$ 4. $(3/4)H$

66. 4
 Sol.

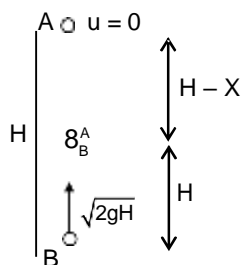

$$H - X = \frac{1}{2}gt^2 \quad \dots(i)$$

$$x = \sqrt{2gH}t - \frac{1}{2}gt^2 \quad \dots(ii)$$

$$H - \sqrt{2gH}t = 0$$

$$t = \frac{H}{\sqrt{2gH}} = \sqrt{\frac{H}{2g}}$$

$$X = \frac{3H}{4}$$

67. After they collide, they stick to each other. What is the loss in their total energy?
 1. 0 2. $(1/2)mgH$
 3. $(3/2)mgH$ 4. $2mgH$

67. 2

Sol. Initial energy = $mgH + \frac{1}{2}m(\sqrt{2gH})^2 = 2mgH$

$$V_1 = 0 + g\left(\sqrt{\frac{H}{2g}}\right) \Rightarrow \frac{\sqrt{gH}}{\sqrt{2}}$$

$$V_2 = \sqrt{2gH} - g\left(\sqrt{\frac{H}{2g}}\right)$$

$$\Rightarrow \sqrt{gH} \left(\sqrt{2} - \frac{1}{\sqrt{2}} \right)$$

$$\Rightarrow \frac{\sqrt{gH}}{2}$$

After collision

$$P_i = P_f$$

$$mv_1 - mv_2 = P_f$$

$$m\left(\frac{\sqrt{gH}}{\sqrt{2}}\right) + m\left(\frac{\sqrt{gH}}{\sqrt{2}}\right) = P_f ; P_f = 0$$

$$\text{Final potential energy} \Rightarrow 2\left(mg\frac{3H}{4}\right) = \frac{3mgH}{2}$$

$$\text{Loss} \Rightarrow 2mgH - \frac{3mgH}{2} = \frac{mgH}{2}$$

68. Given below are two different graphs of variation of density (or pressure) of the medium with position (Fig. 1) and with time (Fig. 2) as a wave passes through the medium.

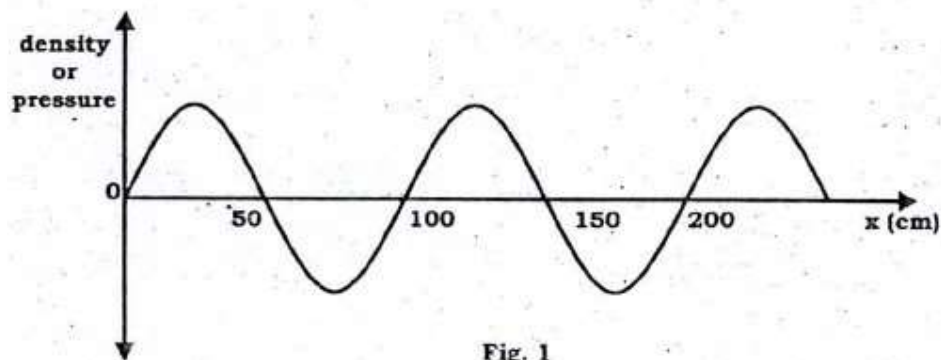

Fig. 1

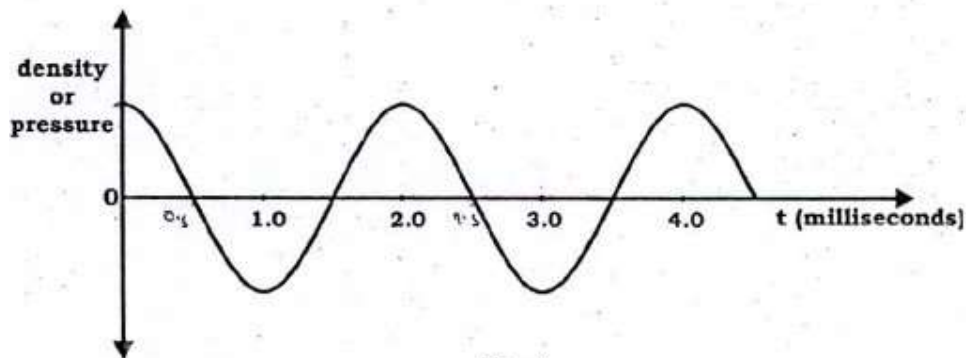

Fig. 2

What will be the speed of the wave in the given medium?

1. 25 m/s
2. 50 m/s
3. 250 m/s
4. 500 m/s

68.

4

Sol.

$$\lambda = 100 \text{ cm}$$

$$T = 2 \text{ ms}$$

$$\lambda = VT$$

$$V = \frac{\lambda}{T} = \frac{100}{2 \times 10^{-3}}$$

$$\Rightarrow \frac{100000}{2} = 50000 \text{ m/s}$$

69.

A convex lens and a concave lens, each of focal length 10 cm, are kept separated by a distance of 2 cm as shown in the figure. If the light is incident from left, the combinations of lenses will be _____.

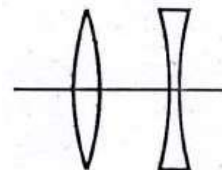

1. converging
2. diverging
3. behaving like a glass slab
4. converging or diverging depending on whether the lenses are arranged as shown in the figure or in the reverse order.

69.

1

Sol.

For convex lens

$$\frac{1}{v} - \frac{1}{u} = \frac{1}{f}$$

$$\frac{1}{v} - \frac{1}{\infty} = \frac{1}{10}$$

For concave lens

$$\frac{1}{v} - \frac{1}{u} = \frac{1}{f}$$

$$\frac{1}{v} - \frac{1}{8} = \frac{1}{-10}$$

$v = 10 \text{ cm}$

$v = +40 \text{ cm}$ Real image

The combinations of lenses will be converging.

70. In the circuit given, the ratio of work done by the battery to maintain the current between point A and B to the work done for the whole circuit is

- 1. $\frac{1}{117}$
- 3. $\frac{1}{12}$

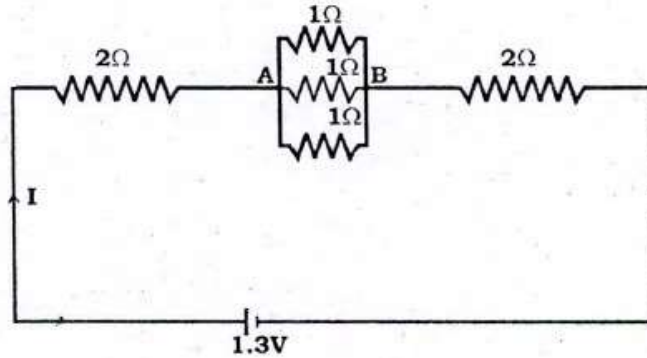

2. $\frac{1}{13}$

4. 1

70. Sol. $R_{AB} = \frac{1}{3}$ $R_{eq} = 4 + \frac{1}{3} \Rightarrow \frac{13}{3}$

$$\frac{W_{AB}}{W_{Total}} = \frac{I^2 R_{AB} t}{I^2 R_{eq} t} \Rightarrow \frac{\frac{1}{3}}{\frac{13}{3}} \Rightarrow \frac{1}{13}$$

71. Magnetic field at the centre of a circular coil of radius R carrying current i is $B \propto \frac{i}{R}$ and its direction is given by right-hand thumb rule. Magnetic field at the centre of circular arc subtending an angle θ (in degree) is $B \propto \frac{i}{R} \left(\frac{\theta}{360^\circ} \right)$ and its direction can be found using right hand rule.

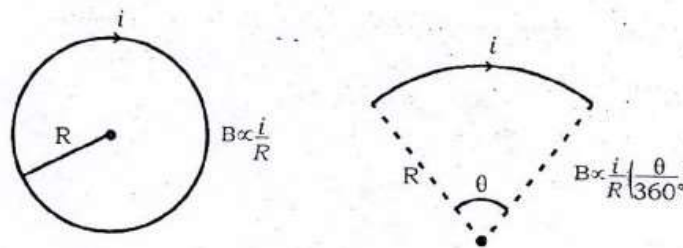

Considering two circular coils made of uniform conductors as shown in figure 3 and 4. In figure 3 points C and D are diametrically opposite to each other, and in figure 4 $\angle PO_2Q = 120^\circ$. Then magnetic fields_____.

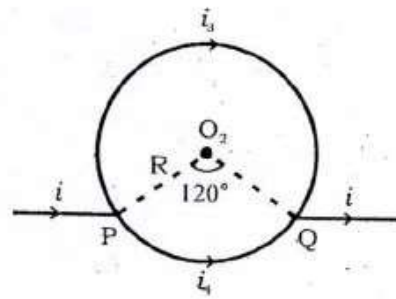
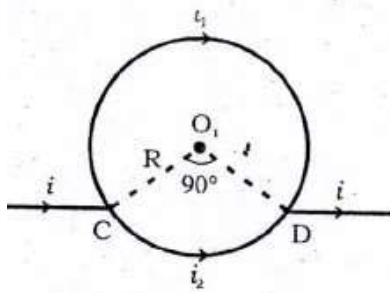

1. at both O_1 and O_2 are zero.
 3. is zero at O_1 but non-zero at O_2

2. at both O_1 and O_2 are non-zero
 4. is non-zero at O_1 but zero at O_2

71.
 Sol.

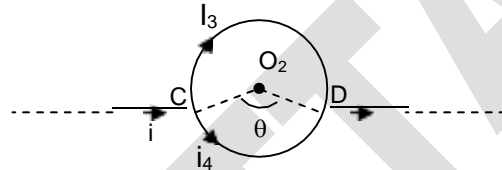
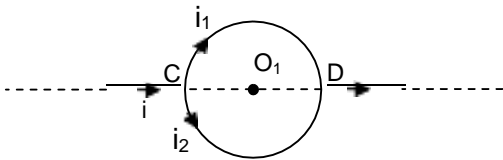

Magnetic field due to circular wire in both cases at the centre is zero. Since magnetic field due to upper wire is equal and opposite to magnetic field of the lower wire at the centre.

72. A pin AB of length 2 cm is kept on the axis of a convex lens between 18 cm and 20 cm as shown in figure. Focal length of convex lens is 10 cm. Find magnification produced for the image of the pin.

1. 0.83
 3. 1.25

2. 1.00
 4. 6.78

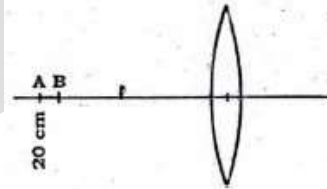

72. 3
 Sol.

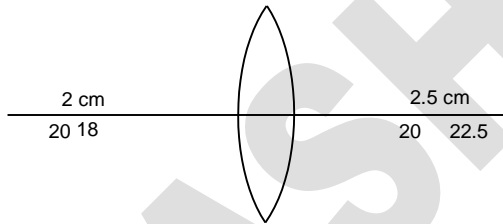

$$\frac{1}{v} - \frac{1}{u} = \frac{1}{f}$$

$$\frac{1}{v} - \frac{1}{-18} = \frac{1}{10}$$

$$\frac{1}{v} = \frac{1}{10} - \frac{1}{18}$$

$$\text{Magnification} = \frac{2.5}{2} \Rightarrow 1.25$$

$$\frac{1}{v} = \frac{18 - 10}{180}$$

$$v = 22.5 \text{ cm}$$

73. What is the current supplied by the battery in the circuit shown below? Each resistance used in circuit is of $1 \text{ k}\Omega$ and potential difference $V_{AB} = 8 \text{ V}$

1. 64 mA
 3. 9.87 mA

2. 15 mA
 4. 1 mA

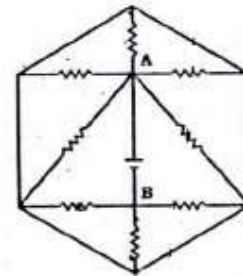

73. 2

Sol.

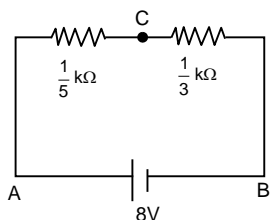

$$R_{\text{eq}} = \frac{1}{\frac{1}{5} + \frac{1}{3}}$$

$$\Rightarrow \frac{15}{8} \text{ k}\Omega$$

$$I = \frac{8 \times 15}{8 \times 10^3} \Rightarrow 15 \text{ mA}$$

74. Read the following statements.

Statement I: Sodium metal reacts violently with water to produce heat and fire.

Statement II: Potassium metal reacts violently with water to form potassium hydroxide and hydrogen gas.

Select the correct answer from the option given below.

1. Statement I is true, Statement II is false.
2. Statement I is false, Statement II is true.
3. Both statements are true, and Statement II provides explanation to Statement I.
4. Both Statements are true but Statement II does not provides explanation to Statement I.

74. 4

Sol. Sodium metal reacts violently with water to produce heat and fire & Potassium metal reacts violently with water to form potassium hydroxide and hydrogen gas therefore both are true and correct statements.

75. You are provided with 18 g each of O_2 , N_2 , CH_4 and H_2O . Which of the following is the correct decreasing order of number of atoms present in these samples?

1. $\text{CH}_4 > \text{H}_2\text{O} > \text{N}_2 > \text{O}_2$
2. $\text{O}_2 > \text{N}_2 > \text{H}_2\text{O} > \text{CH}_4$
3. $\text{CH}_4 > \text{N}_2 > \text{O}_2 > \text{H}_2\text{O}$
4. $\text{N}_2 > \text{H}_2\text{O} > \text{O}_2 > \text{CH}_4$

75. 1
Sol.

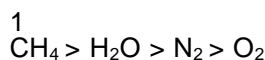

$$\text{No. of atoms of } \text{O}_2 = \frac{18}{32} \times 2 \times N_A = 1.125 N_A$$

$$\text{No. of atoms of } \text{N}_2 = \frac{18}{28} \times 2 \times N_A = 1.285 N_A$$

$$\text{No. of atoms of } \text{CH}_4 = \frac{18}{16} \times 5 \times N_A = 5.625 N_A$$

$$\text{No. of atoms of } \text{H}_2\text{O} = \frac{18}{18} \times 3 \times N_A = 3 N_A$$

76. Manya, Kartik, Gurnoor and Sheena had arranged the ions F^- , Na^+ , O^{2-} and Mg^{2+} in decreasing orders of their ionic radii.

Manya – $\text{O}^{2-} > \text{Mg}^{2+} > \text{F}^- > \text{Na}^+$

Kartik – $\text{Mg}^{2+} > \text{Na}^+ > \text{O}^{2-} > \text{F}^-$

Gurnoor – $\text{O}^{2-} > \text{F}^- > \text{Na}^+ > \text{Mg}^{2+}$

Sheena – $\text{F}^- > \text{Na}^+ > \text{O}^{2-} > \text{Mg}^{2+}$

Who had provided the correct order of their decreasing ionic radii?

1. Manya
2. Kartik
3. Gurnoor
4. Sheena

76. 3

Sol. Gurnoor provided the correct order of decreasing ionic radii i.e. $\text{O}^{2-} > \text{F}^- > \text{Na}^+ > \text{Mg}^{2+}$
 F^- , Na^+ , O^{2-} , Mg^{2+} are isoelectronic species each containing 10 electrons.

77. An organic compound A on heating with concentrated H_2SO_4 gave product B and on warming with alkaline KMnO_4 gave compound C. Compound A on heating with compound C in presence of concentrated H_2SO_4 formed compound D, which has fruity smell.

Identify the compounds A, B, C and D.

1. A = Alcohol, B = Carboxylic acid, C = Alkene, D = Ester

2. A = Carboxylic acid, B = Ester, C = Alkene, D = Alcohol
 3. A = Alcohol, B = Alkene, C = Carboxylic acid, D = Ester
 4. A = Alkene, B = Alcohol, C = Ester, D = Carboxylic acid

77. 3

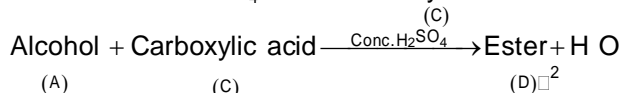
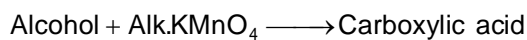
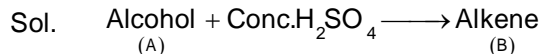

A = Alcohol, B = Alkene, C = Carboxylic acid, D = Ester

78. Match List I (Mixture) and List II (Type) with the List III (Example) and select the correct answer from the combinations given below:

List I (Mixture)	List II (Type)	List III (Example)
A. Liquid in gas	1. Emulsion	I. Mist
B. Liquid in liquid	2. Aerosol	II. Sponge
C. Gas in solid	3. Foam	III. Face cream
	4. Gel	IV. Butter

1. A-3-II, B-2-III, C-4-IV
 3. A-1-III, B-2-II, C-3-I

2. A-2-1, B-1-III, C-3-II
 4. A-1-II, B-4-I, C-2-III

78. 2

Sol. A-2-1, B-1-III, C-3-II

Mixture	Type	Example
A. Liquid in gas	Aerosol	Mist
B. Liquid in liquid	Emulsion	Face cream
C. Gas in solid	Foam	Sponge

79. Which of the following set of reactions will **NOT** occur?

- I. $\text{MgSO}_4(\text{aq}) + \text{Fe}(\text{s}) \rightarrow \text{FeSO}_4(\text{aq}) + \text{Mg}(\text{s})$
 II. $\text{CuSO}_4(\text{aq}) + \text{Fe}(\text{s}) \rightarrow \text{FeSO}_4(\text{aq}) + \text{Cu}(\text{s})$
 III. $\text{MgSO}_4(\text{aq}) + \text{Cu}(\text{s}) \rightarrow \text{CuSO}_4(\text{aq}) + \text{Mg}(\text{s})$
 IV. $\text{CuSO}_4(\text{aq}) + \text{Zn}(\text{s}) \rightarrow \text{ZnSO}_4(\text{aq}) + \text{Cu}(\text{s})$

1. I and III
 2. II and IV
 3. I, II and III
 4. II, III and IV

79. 1

Sol. According to reactivity series of metals

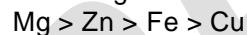

Reaction - I: $\text{MgSO}_4(\text{aq}) + \text{Fe}(\text{s}) \longrightarrow$ will not occur

Since Fe is less reactive than Mg, so no reaction will take place.

Reaction : III: $\text{MgSO}_4(\text{aq}) + \text{Cu}(\text{s}) \longrightarrow$ will not occur

Since Cu is less reactive than Mg, so no reaction will take place.

80. Two organic compounds 'A' and 'B' react with sodium metal and both produce the same gas 'X', but with sodium hydrogen carbonate only compound B reacts to give a gas 'Y'. Identify 'A', 'B', 'X' and 'Y':

1. A = Ethylene, B = Ethyl Alcohol, X = Carbon dioxide, Y = Hydrogen
 2. A = Ethyl Alcohol, B = Acetic acid, X = Hydrogen, Y = Carbon dioxide
 3. A = Methyl alcohol, B = Ethyl alcohol, X = Hydrogen, Y = Carbon dioxide
 4. A = Acetic acid, B = Formic acid, X = Carbon dioxide, Y = Hydrogen

80. 2

Sol. Ethyl alcohol and acetic acid can both react with sodium metal and both produce same gas 'X'.

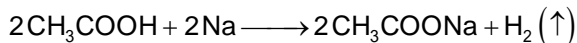
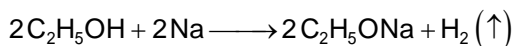

Gas X is hydrogen

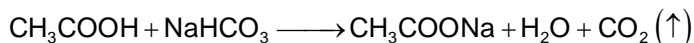

Gas Y is carbon dioxide

A = Ethyl alcohol, B = Acetic acid, X = Hydrogen, Y = Carbon dioxide

81. Consider the elements A, B, C and D with atomic numbers 11, 12, 16 and 17, respectively. Which among the following statements regarding these elements are correct?

- I. The element C will gain electron more easily than element D
- II. The element B tends to lose electron more readily than C
- III. The oxide of A will be least basic while that of D will be most basic
- IV. The energy required to remove an electron from outermost shell from A will be minimum while that from D will be maximum.

1. I and III only
2. I and IV only
3. II and III only
4. II and IV only

81. 4

Sol.

	A	B	C	D
Atomic number	11	12	16	17
Electronic configuration	2, 8, 1	2, 8, 2	2, 8, 6	2, 8, 7

Therefore, statement II & IV are correct

82. The following observations are given for four metals:

- I. Metal H does not react with dilute HCl
- II. Metal K reacts with warm water
- III. Metal L does not react with water but displaces metal H from its aqueous salt solution
- IV. Metal M reacts with cold water

Choose the correct decreasing order of reactivity of these metals amongst the following.

1. $M > L > H > K$
2. $K > M > H > L$
3. $M > K > L > H$
4. $L > H > K > M$

82. 3

Sol.

Correct decreasing order of reactivity of these metals is:

$M > K > L > H$

83. Match chemical reactions given in the List-I with the type of chemical reactions given in List-II and select the correct answer using the options given below:

List – I (Chemical reactions)		List – II (Type of chemical reactions)	
(A)	Formation of NH_3 from N_2 and H_2	I	Decomposition
(B)	Calcination of zinc carbonate	II	Double displacement
(C)	Reaction of aqueous BaCl_2 solution with dilute H_2SO_4	III	Combination
(D)	Rancidity of oils	IV	Redox
		V	Displacement

1. A –I, B –V, C-III, D-IV

2. A –III, B –IV, C-V, D-I

3. A –IV, B –III, C-V, D-I

4. A –III, B –I, C-II, D-IV

83. 4

Sol.

A –III, B –I, C-II, D-IV

A	Formation of NH_3 from N_2 & H_2	Combination
B.	Calcination of zinc carbonate	Decomposition
C.	Reaction of aqueous BaCl_2 solution with dilute H_2SO_4	Double displacement
D.	Rancidity of oils	Redox

84. You are provided with aqueous solutions of three salts- A,B and C, 2-3 drops of blue litmus solution, red litmus solution and phenolphthalein were added to each of these solution in separate experiments. The change in colours of different indicators were recorded in the following table.

Sample	With blue litmus solution	With red litmus solution	With phenolphthalein solution
A	No change	No change	No change
B	Turns red	No change	No change
C	No change	Turns blue	Turns pink

On the basis of above observations, identify A, B and C from the following options:

1. A = NH_4Cl , B = NaCl , C = CH_3COONa 2. A = NH_4Cl , B = CH_3COONa , C = NaCl
 3. A = NaCl , B = NH_4Cl , C = CH_3COONa 4. A = CH_3COONa , B = NH_4Cl , C = NaCl

84. 3

Sol. A = NaCl (neutral in nature)
 B = NH_4Cl (Acidic in nature)
 C = CH_3COONa (Basic in nature)

85. Match List-I (Mixture to be separated) with the List-II (Method used) and select the correct answer using the options given below:

List – I (Mixture to be separated)		List – II (Method used)	
(A)	Liquid N_2 and liquid O_2	I	Chromatography
(B)	Red and Blue inks	II	Sublimation
(C)	Solution of NaCl in water	III	Fractional distillation
(D)	Naphthalene and NaCl	IV	Evaporation
		V	Crystallisation

1. A-I, B-II, C-IV, D-V 2. A-III, B-V, C-II, D-IV
 3. A-III, B-I, C-IV, D-II 4. A-III, B-IV, C-I, D-II

85. 3

Sol. A-III, B-I, C-IV, D-II
 Liquid N_2 and liquid $\text{O}_2 \rightarrow$ Fractional distillation
 Red and Blue inks \rightarrow Chromatography
 Solution of NaCl in water \rightarrow Evaporation
 Naphthalene and $\text{NaCl} \rightarrow$ Sublimation

86. Select the correct set of statements regarding change in properties, as we move down the second group in periodic table.

- I. Atomic size increases
 II. Electronegativity increases
 III. Tendency to lose electrons increases
 IV. Valency remains same

1. I, II and III 2. II, III and IV
 3. I, II and IV 4. I, III and IV

86. 4

Sol. I, III & IV statements are correct, as we move down the second group in periodic table the following change in properties occur:

Atomic size increases, tendency to lose electrons increases but valency remains same

87. Which of the following options containing formula, bonding and nature of aqueous solution respectively is correct for the compound formed by two elements A and B having atomic numbers 1 and 17, respectively?

1. AB , Ionic, Acidic 2. AB_2 , Ionic, Basic
 3. AB , Covalent, Acidic 4. AB_2 , Covalent, Neutral

87. 3

Sol. Formula of compound is **AB** (HCl), which has **covalent bond** and its aqueous solution is **acidic** in nature.

88. Choose one of the following alternative statements given below which correctly explains the process of osmosis.

1. Movement of water from regions of concentrated to dilute solutions.
2. The passage of solute from weak solution to strong solution through a selectively-permeable membrane.
3. A passive transport of a solvent through a selectively-permeable membrane from a region of low solute concentration to a region of high solute concentration.
4. An energy-dependent transport of a solvent through a selectively-permeable membrane from a region of low solute concentration to a region of high solute concentration.

88. 3

Sol. The correct statement is a passive transport of a solvent through a selectively-permeable membrane from a region of low solute concentration to a region of high solute concentration.

89. In meiosis each of the four daughter cells have one set of chromosomes. Due to randomness of process of chromosome separation in meiosis, larger number of chromosome combinations can form gametes. How many such chromosome combinations in the gametes are possible in case of humans, assuming there is no crossing-over taking place?

1. 2^{22}
2. 2^{23}
3. 2^{46}
4. 2^{34}

89. 2

Sol. 2^{23} chromosome combinations in the gametes are possible in case of humans, assuming there is no crossing-over taking place.

90. Sclerenchyma in plants is an example of simple permanent tissue comprising of two types of cells, sclereids and fibres. Why these cells are functionally important to the plants even after they die?

Choose the correct alternative from the options given below.

1. Both are thin walled cells lacking intercellular spaces
2. Walls in both the types of cells are thick and cutinized
3. Walls in both the cell types are thick and usually lignified
4. Both the cells are used for conducting solutes and providing strength to the plant

90. 3

Sol. Sclerenchyma cells are functionally important to the plants even after they die because cell wall in both the cell types are thick and usually lignified.

91. Which one of the following organisms has a cellular respiratory pigment dissolved in plasma and is also a predaceous carnivore and shows matriphagy?

1. Scorpion
2. Cockroach
3. Earthworm
4. Sea cucumber

91. 1

Sol. Scorpion organisms has a cellular respiratory pigment (haemocyanin) dissolved in plasma and is also a predaceous carnivore and shows matriphagy.

92. Lichens are sensitive to certain air pollutants and are often replaced by other plants. From the given options choose the best combination of sensitivity and replacement of lichens.

1. Sulphur dioxide and moss
2. Sulphur dioxide and algae
3. Carbon dioxide and ferns
4. Sulphurdioxide and grass

92. 1

Sol. The best combination of sensitivity and replacement of lichens during air pollution is Sulphur dioxide and moss.

93. A student was performing an experiment to understand the enzyme-substrate reaction. The student measured the formation of coloured product using a colorimeter. The student plotted the graph below which shows the reaction rate versus the substrate concentration.

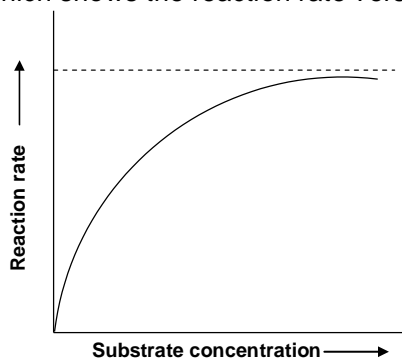

Following interpretations were drawn by the student:

- The higher concentration of substrate acts as an enzyme inhibitor.
- It is sigmoidal curve with sharp transition from low to high reactions rates over the increasing substrate concentration.
- The curve reaches a plateau and does not further increase with increasing substrate concentrations due to saturation of enzyme with the substrate.

Choose which of the interpretations of the graph are correct.

- | | |
|------------|------------|
| 1. A and B | 2. A and C |
| 3. B only | 4. B and C |

93. 4

Sol. The best interpretation were drawn the student by graph are it is sigmoidal curve with sharp transition from low to high reactions rates over the increasing substrate concentration and the curve reaches a plateau and does not further increase with increasing substrate concentrations due to saturation of enzyme with the substrate

94. Glucose is the prime source of energy in our body. However it is stored in the form of glycogen in the muscle and liver of animals and in the form of starch in plants. As a result, every time a cell requires glucose, it must hydrolyze glycogen which is an energy consuming process. Why does the cell store glycogen instead of glucose in free form?

- Glycogen is more compact and more hydrophilic
- Storage of glucose in free form will consume more ATP
- Glucose in the free form creates more osmotic pressure
- Glucose is highly reactive molecule hence storing in the free form can result in unwanted reactions in the cells.

94. 3

Sol. Glycogen is insoluble thus storing it as Glycogen will not upset the osmotic pressure rather than glucose which is soluble in water and if it is stored as glucose it will disturb the osmotic pressure (hypertonic) that will cause cell to lyse.

95. The figure given below is designed to show yeast respiration. In one of the tubes, there is yeast suspension in glucose solution. This solution was boiled before yeast was added to it. Which one of the following is the possible reason for boiling of sugar solution?

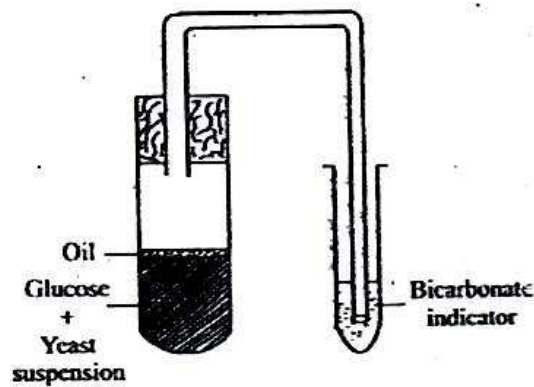

1. To ensure aerobic fermentation
2. To provide the initial warmth for the yeast to become active
3. To remove the dissolved oxygen and carbon dioxide from the solution
4. To remove dissolved carbon dioxide and trap the oxygen from the atmosphere

95. 3

Sol. The possible reason for boiling of sugar solution in given setup is to remove the dissolved oxygen and carbon dioxide from the solution.

96. A squirrel was eating a fruit on the ground. Suddenly it was attacked by a dog. The squirrel rushed to the tree immediately and saved itself from the dangerous attack. What immediate changes are most likely to have taken place in the body of the squirrel?

- (A) Blood flows to the stomach for rapid digestion.
- (B) Adrenalin was secreted in the blood by the adrenal glands
- (C) Heart beat becomes faster and pumps more blood so that muscles get more oxygen
- (D) Adrenocorticotrophic hormone is secreted in the blood and blood flows more towards the vital organs.

Select the correct combination of options given below.

- | | |
|------------|------------|
| 1. A and B | 2. A and C |
| 3. B and C | 4. C and D |

96. 3

Sol. During emergency situation Adrenalin secreted in the blood by the adrenal glands due to which Heart beat becomes faster and pumps more blood so that muscles get more oxygen.

97. Stimulus from the environment is detected by the nerve cells. The stimulus acquired is transmitted in the form of electrical impulse. From the options given below choose the correct scheme showing the direction in which the nerve impulse travels. (Arrows shows the direction of impulse flow)

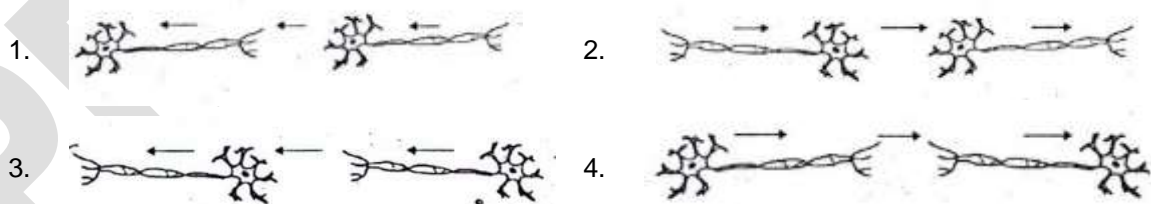

97. 3

Sol. The direction in which nerve impulse travels is towards the dendrites and away from the axon (unidirectional)

98. "Double fertilization" is a complex mechanism of flowering plants that is also unique to angiosperms. Choose the most appropriate statement from the options listed below the explains this phenomenon.

1. Fertilization in two flowers of the same plant forming endosperms

2. Two male gametes fertilize two eggs inside the ovule as a result the ovary gives rise to bigger fruits
3. Two fertilizations occur in a flower-one fertilization results in the formation of a diploid zygote and the second fertilization results in the formation of a triploid endosperm.
4. Two pollen grains sending two pollen tubes inside the ovary, resulting in the formation of two seeds inside the fruit.

98. 3

Sol. The most appropriate statement which explains the phenomenon of double fertilization is two fertilizations occur in a flower-one fertilization results in the formation of a diploid zygote and the second fertilization results in the formation of a triploid endosperm.

99. It is generally observed that malaria is rampant in areas where construction work and/or stagnant water are usually seen. Plasmodium species are known to cause malaria. The parasite when injected by the mosquito into the human blood stream goes through specific life cycle stages. Select from below the correct sequence of stages.

1. Mosquito (sporozoites) → human liver (merozoites) → human RBC (gametes) → mosquito (zygote-oocyst-sporozoites)
2. Mosquito (merozoites) → human RBC (gametes) → human liver (sporozoites) → mosquito (oocyst-zygote- sporozoites)
3. Mosquito (merozoites) → human liver (sporozoites) → human RBC (gametes) → mosquito (oocyst- zygote-sporozoites)
4. Mosquito (sporozoites) → human liver (sporozoites) → human RBC (merozoites) → mosquito (zygote-oocyst-sporozoites)

99. 1

Sol. The correct sequence of stages is:

Mosquito (sporozoites) → human liver (merozoites) → human RBC (gametes) → mosquito (zygote-oocyst-sporozoites)

100. A plant with red coloured flowers is crossed with a plant having white flowers. The red and white colour of the flower is controlled by a single gene. Red is dominant over white. The F_1 progeny is self-pollinated and the flower colour in F_2 is observed.

Given the above information, what is the expected phenotypic ratio of plants with different flower colours.

1. All plants with red flowers
2. Red: white in the ratio of 3 : 1
3. Pink: white in the ratio of 3 : 1
4. Red: pink: white in a ratio of 1 : 2 : 1

100. 2

Sol. Red colour is dominant over white

RR → Red colour

rr → white colour

F_0 RR × rr
 F_1 Rr

		R	r
R	RR	Rr	
r	Rr	rr	

Result of F_2 generation Red : White → 3 : 1